

Cambridge  
International  
AS & A Level

**Cambridge International Examinations**  
Cambridge International Advanced Subsidiary and Advanced Level

CANDIDATE  
NAME

CENTRE  
NUMBER

--	--	--	--	--

CANDIDATE  
NUMBER

--	--	--	--

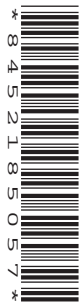

**PHYSICS**

**9702/42**

Paper 4 A Level Structured Questions

**October/November 2017**

**2 hours**

Candidates answer on the Question Paper.

No Additional Materials are required.

**READ THESE INSTRUCTIONS FIRST**

Write your Centre number, candidate number and name on all the work you hand in.

Write in dark blue or black pen.

You may use an HB pencil for any diagrams or graphs.

Do not use staples, paper clips, glue or correction fluid.

DO **NOT** WRITE IN ANY BARCODES.

Answer **all** questions.

Electronic calculators may be used.

You may lose marks if you do not show your working or if you do not use appropriate units.

At the end of the examination, fasten all your work securely together.

The number of marks is given in brackets [ ] at the end of each question or part question.

This document consists of **27** printed pages and **1** blank page.

## 2

**Data**

speed of light in free space	$c = 3.00 \times 10^8 \text{ m s}^{-1}$
permeability of free space	$\mu_0 = 4\pi \times 10^{-7} \text{ H m}^{-1}$
permittivity of free space	$\epsilon_0 = 8.85 \times 10^{-12} \text{ F m}^{-1}$
	$(\frac{1}{4\pi\epsilon_0} = 8.99 \times 10^9 \text{ m F}^{-1})$
elementary charge	$e = 1.60 \times 10^{-19} \text{ C}$
the Planck constant	$h = 6.63 \times 10^{-34} \text{ J s}$
unified atomic mass unit	$1 \text{ u} = 1.66 \times 10^{-27} \text{ kg}$
rest mass of electron	$m_e = 9.11 \times 10^{-31} \text{ kg}$
rest mass of proton	$m_p = 1.67 \times 10^{-27} \text{ kg}$
molar gas constant	$R = 8.31 \text{ J K}^{-1} \text{ mol}^{-1}$
the Avogadro constant	$N_A = 6.02 \times 10^{23} \text{ mol}^{-1}$
the Boltzmann constant	$k = 1.38 \times 10^{-23} \text{ J K}^{-1}$
gravitational constant	$G = 6.67 \times 10^{-11} \text{ N m}^2 \text{ kg}^{-2}$
acceleration of free fall	$g = 9.81 \text{ m s}^{-2}$

**Formulae**

uniformly accelerated motion	$s = ut + \frac{1}{2}at^2$ $v^2 = u^2 + 2as$
work done on/by a gas	$W = p\Delta V$
gravitational potential	$\phi = -\frac{Gm}{r}$
hydrostatic pressure	$p = \rho gh$
pressure of an ideal gas	$p = \frac{1}{3} \frac{Nm}{V} \langle c^2 \rangle$
simple harmonic motion	$a = -\omega^2 x$
velocity of particle in s.h.m.	$v = v_0 \cos \omega t$ $v = \pm \omega \sqrt{(x_0^2 - x^2)}$
Doppler effect	$f_o = \frac{f_s v}{v \pm v_s}$
electric potential	$V = \frac{Q}{4\pi\epsilon_0 r}$
capacitors in series	$1/C = 1/C_1 + 1/C_2 + \dots$
capacitors in parallel	$C = C_1 + C_2 + \dots$
energy of charged capacitor	$W = \frac{1}{2} QV$
electric current	$I = Anvq$
resistors in series	$R = R_1 + R_2 + \dots$
resistors in parallel	$1/R = 1/R_1 + 1/R_2 + \dots$
Hall voltage	$V_H = \frac{BI}{ntq}$
alternating current/voltage	$x = x_0 \sin \omega t$
radioactive decay	$x = x_0 \exp(-\lambda t)$
decay constant	$\lambda = \frac{0.693}{t_{\frac{1}{2}}}$

Answer **all** the questions in the spaces provided.

- 1 (a) State Newton's law of gravitation.

.....

.....

.....[2]

- (b) The planet Jupiter and one of its moons, Io, may be considered to be uniform spheres that are isolated in space.

Jupiter has radius  $R$  and mean density  $\rho$ .

Io has mass  $m$  and is in a circular orbit about Jupiter with radius  $nR$ , as illustrated in Fig. 1.1.

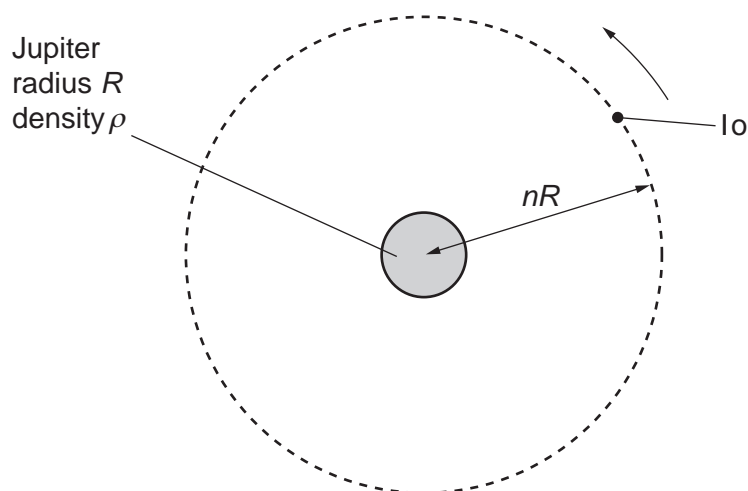

**Fig. 1.1**

The time for Io to complete one orbit of Jupiter is  $T$ .

Show that the time  $T$  is related to the mean density  $\rho$  of Jupiter by the expression

$$\rho T^2 = \frac{3\pi n^3}{G}$$

where  $G$  is the gravitational constant.

[4]

5

- (c) (i) The radius  $R$  of Jupiter is  $7.15 \times 10^4$  km and the distance between the centres of Jupiter and Io is  $4.32 \times 10^5$  km.  
The period  $T$  of the orbit of Io is 42.5 hours.

Calculate the mean density  $\rho$  of Jupiter.

$$\rho = \dots\dots\dots \text{ kg m}^{-3} \text{ [3]}$$

- (ii) The Earth has a mean density of  $5.5 \times 10^3 \text{ kg m}^{-3}$ . It is said to be a planet made of rock. By reference to your answer in (i), comment on the possible composition of Jupiter.

.....  
.....[1]

[Total: 10]

- 2 (a) State what is meant by *specific latent heat*.

.....

.....

.....[2]

- (b) A beaker of boiling water is placed on the pan of a balance, as illustrated in Fig. 2.1.

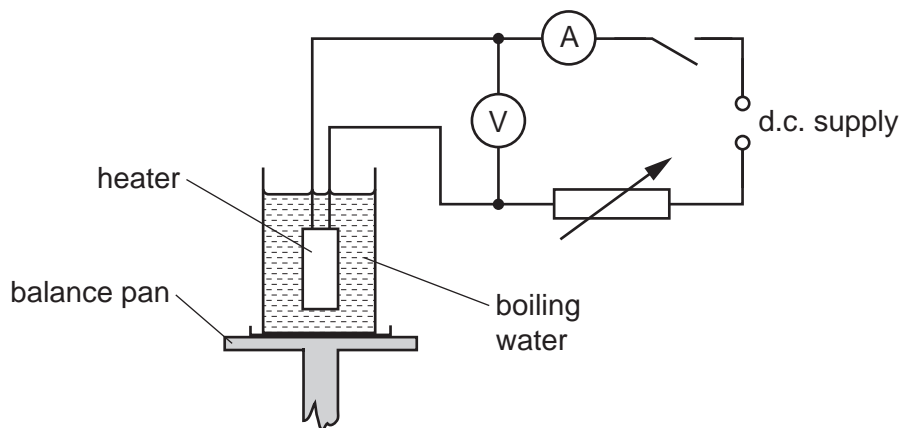

Fig. 2.1

The water is maintained at its boiling point by means of a heater.  
 The change  $M$  in the balance reading in 300 s is determined for two different input powers to the heater.  
 The results are shown in Fig. 2.2.

voltmeter reading / V	ammeter reading / A	$M/g$
11.5	5.2	5.0
14.2	6.4	9.1

Fig. 2.2

- (i) Energy is supplied continuously by the heater.  
 State where, in this experiment,

1. external work is done,

.....

.....

2. internal energy increases. Explain your answer.

.....

.....

.....

[3]

7

- (ii) Use data in Fig. 2.2 to determine the specific latent heat of vaporisation of water.

specific latent heat = .....  $\text{J g}^{-1}$  [3]

[Total: 8]

3 (a) (i) Define the *radian*.

.....  
 .....  
 .....[2]

(ii) State, by reference to simple harmonic motion, what is meant by *angular frequency*.

.....  
 .....[1]

(b) A thin metal strip, clamped horizontally at one end, has a load of mass  $M$  attached to its free end, as shown in Fig. 3.1.

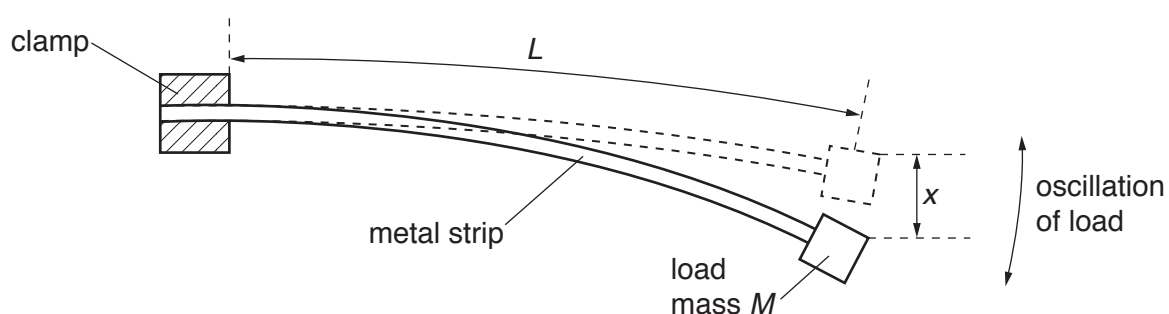

Fig. 3.1

The metal strip bends, as shown in Fig. 3.1.

When the free end of the strip is displaced vertically and then released, the mass oscillates in a vertical plane.

Theory predicts that the variation of the acceleration  $a$  of the oscillating load with the displacement  $x$  from its equilibrium position is given by

$$a = -\left(\frac{c}{ML^3}\right)x$$

where  $L$  is the effective length of the metal strip and  $c$  is a positive constant.

(i) Explain how the expression shows that the load is undergoing simple harmonic motion.

.....  
 .....  
 .....  
 .....[2]



9

- (ii) For a metal strip of length  $L = 65\text{ cm}$  and a load of mass  $M = 240\text{ g}$ , the frequency of oscillation is  $3.2\text{ Hz}$ .  
Calculate the constant  $c$ .

$c = \dots\dots\dots \text{ kg m}^3 \text{ s}^{-2}$  [3]

[Total: 8]



(b) Ultrasound frequencies as high as 10 MHz are used in medical diagnosis. Suggest one advantage of the use of high-frequency ultrasound rather than lower-frequency ultrasound.

.....  
.....  
.....[1]

[Total: 6]

- 5 The analogue signal from a microphone is to be transmitted in digital form. The variation with time  $t$  of part of the signal from the microphone is shown in Fig. 5.1.

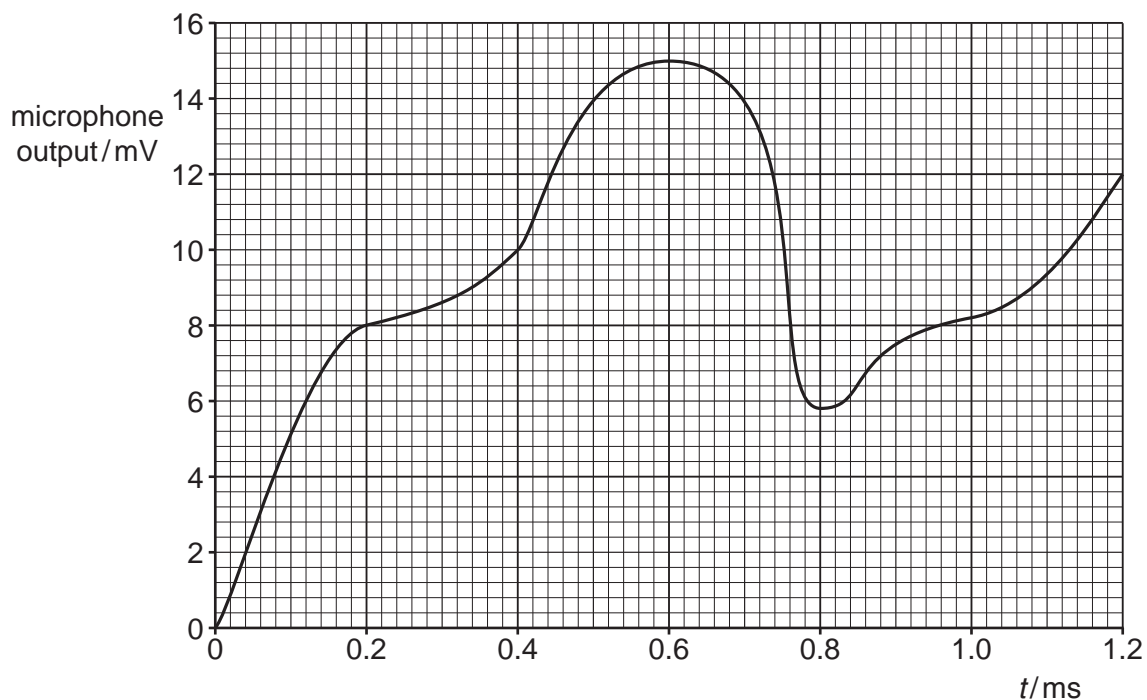

Fig. 5.1

The microphone output is sampled at a frequency of 5.0 kHz by an analogue-to-digital converter (ADC).

The output from the ADC is a series of 4-bit numbers. The smallest bit represents 1.0 mV.

The first sample is taken at time  $t = 0$ .

- (a) Use Fig. 5.1 to complete Fig. 5.2.

time $t$ /ms	microphone output/mV	ADC output
0.2	.....	.....
0.8	.....	.....

Fig. 5.2

[2]

(b) After transmission of the digital signal, it is converted back to an analogue signal using a digital-to-analogue converter (DAC).

Using data from Fig. 5.1, draw, on the axes of Fig. 5.3, the output level from the DAC for the transmitted signal from time  $t = 0$  to time  $t = 1.2$  ms.

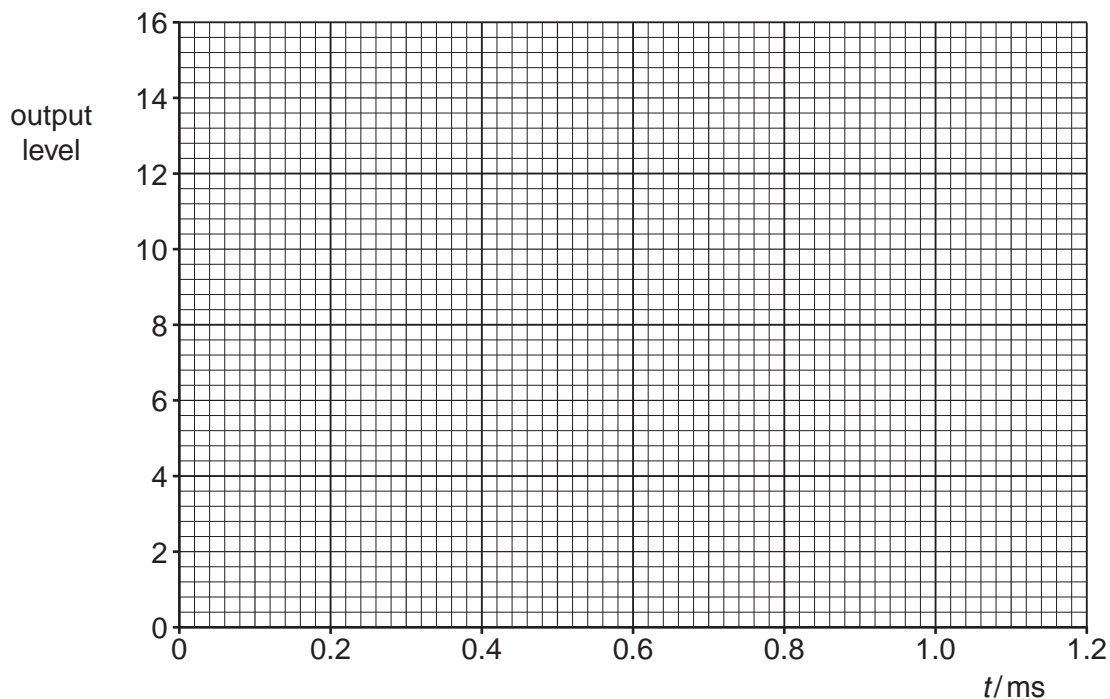

Fig. 5.3

[4]

(c) It is usual in modern telecommunication systems for the ADC and the DAC to have more than four bits in each sample.

State and explain the effect on the transmitted analogue signal of such an increase.

.....

.....

.....

..... [2]

[Total: 8]

- 6 (a) For any point outside a spherical conductor, the charge on the sphere may be considered to act as a point charge at its centre. By reference to electric field lines, explain this.

.....

.....

.....

.....[2]

- (b) An isolated spherical conductor has charge  $q$ , as shown in Fig. 6.1.

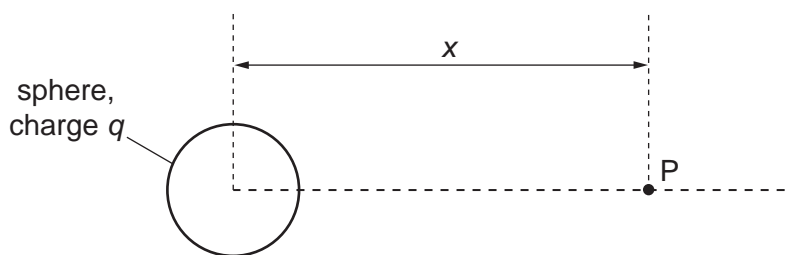

Fig. 6.1

Point P is a movable point that, at any one time, is a distance  $x$  from the centre of the sphere.

The variation with distance  $x$  of the electric potential  $V$  at point P due to the charge on the sphere is shown in Fig. 6.2.

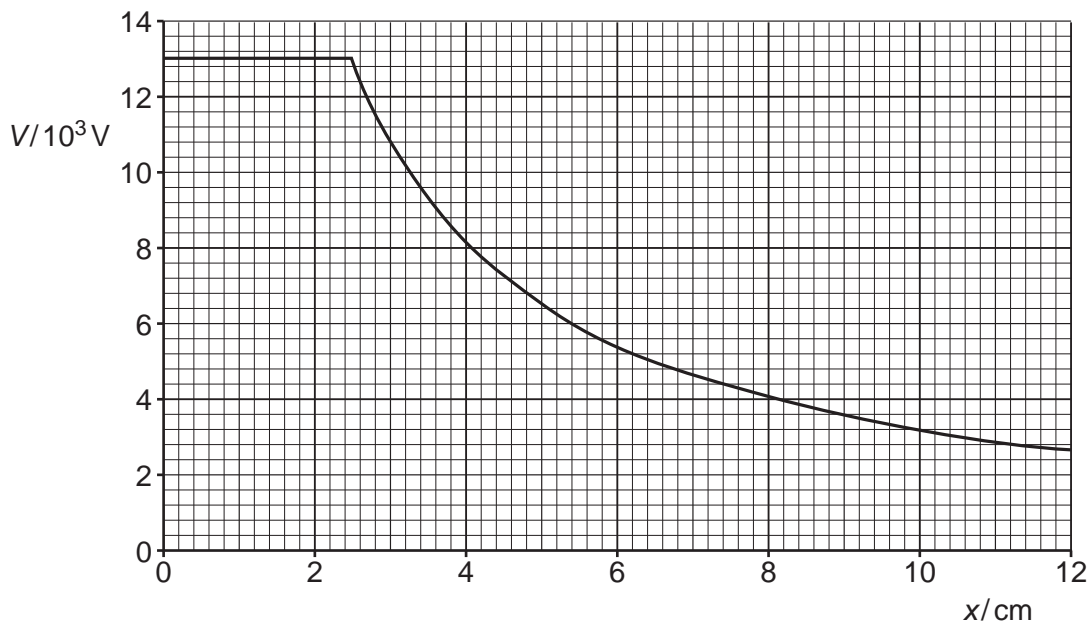

Fig. 6.2

15

Use Fig. 6.2 to determine

- (i) the electric field strength  $E$  at point P where  $x = 6.0\text{ cm}$ ,

$$E = \dots\dots\dots \text{ NC}^{-1} \text{ [3]}$$

- (ii) the radius  $R$  of the sphere. Explain your answer.

$$R = \dots\dots\dots \text{ cm [2]}$$

[Total: 7]

7 (a) Feedback is used frequently in amplifier circuits.

State

(i) what is meant by *feedback*,

.....  
 .....  
 ..... [2]

(ii) two benefits of negative feedback in an amplifier circuit.

1. ....  
 .....  
 2. ....  
 ..... [2]

(b) An amplifier circuit incorporating an ideal operational amplifier (op-amp) is used to amplify the output of a microphone. The circuit is shown in Fig. 7.1.

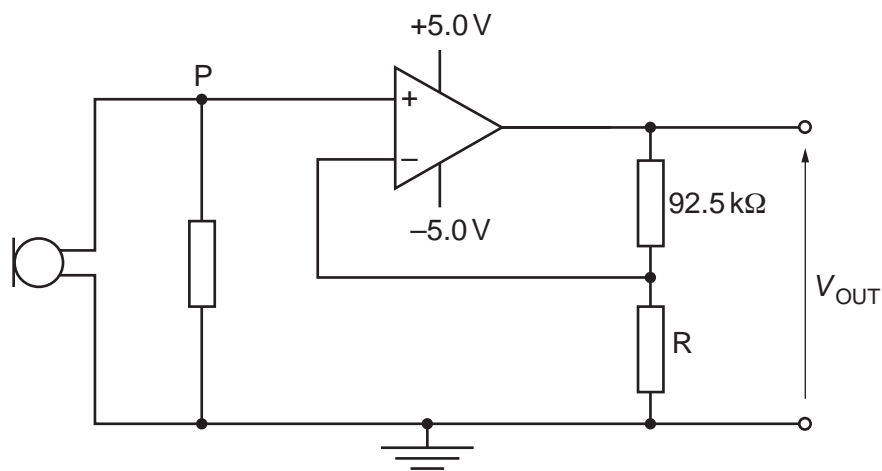

Fig. 7.1



When the potential at point P is 48 mV, the output potential difference  $V_{OUT}$  is 3.6 V.

(i) Determine

1. the gain of the amplifier circuit,

gain = ..... [2]

2. the resistance of resistor R.

resistance = .....  $\Omega$  [2]

(ii) State and explain the effect on the amplifier output when the potential at P exceeds 68 mV.

.....  
.....  
..... [2]

[Total: 10]

- 8 A thin slice of conducting material is placed normal to a uniform magnetic field, as shown in Fig. 8.1.

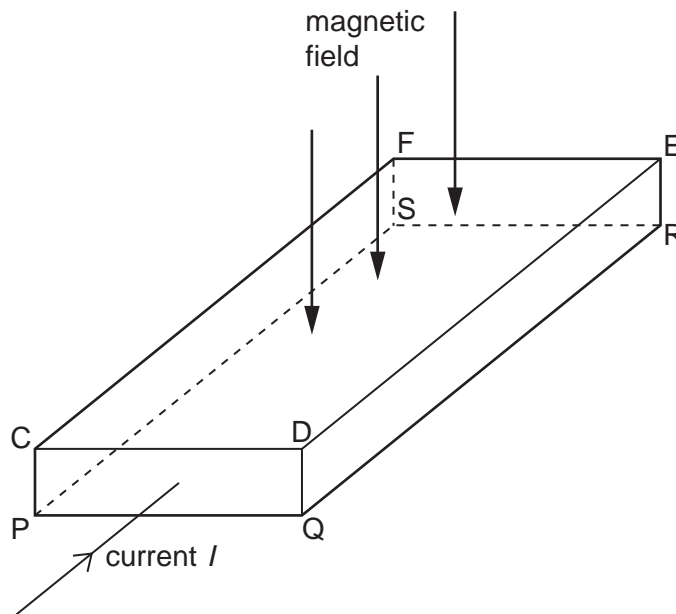

Fig. 8.1

The magnetic field is normal to face CDEF and to face PQRS.

The current  $I$  in the slice is normal to the faces CDQP and FERS.

A potential difference, the Hall voltage  $V_H$ , is developed across the slice.

- (a) (i) State the faces between which the Hall voltage  $V_H$  is developed.

..... and ..... [1]

- (ii) Explain why a constant voltage  $V_H$  is developed between the faces you have named in (i).

.....  
 .....  
 .....  
 .....  
 .....  
 .....  
 .....  
 .....  
 .....  
 ..... [4]

- (b) Two slices have similar dimensions. One slice is made of a metal and the other slice is made of a semiconductor material.

For the same values of magnetic flux density and current, state which slice, if either, will give rise to the larger Hall voltage. Explain your reasoning.

.....

.....

.....

..... [2]

[Total: 7]

9 (a) State what is meant by a *field of force*.

.....  
.....  
.....[2]

(b) Explain the use of a uniform magnetic field and a uniform electric field for the selection of the velocity of charged particles. You may draw a diagram if you wish.

.....  
.....  
.....  
.....  
.....  
.....[4]

- (c) A beam of charged particles enters a region of uniform magnetic and electric fields, as illustrated in Fig. 9.1.

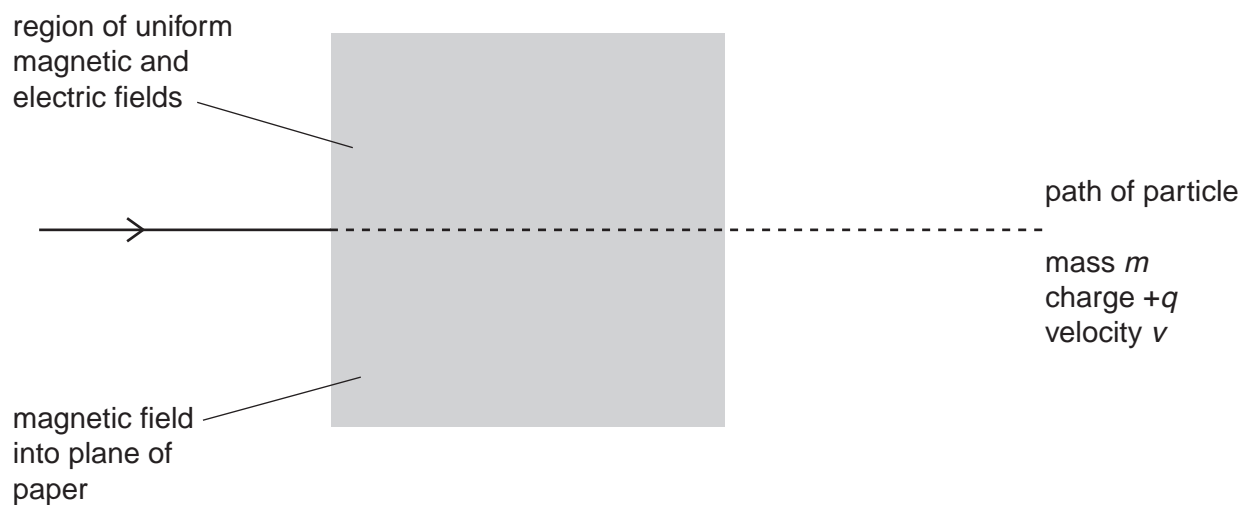

**Fig. 9.1**

The direction of the magnetic field is into the plane of the paper. The velocity of the charged particles is normal to the magnetic field as the particles enter the field.

A particle in the beam has mass  $m$ , charge  $+q$  and velocity  $v$ . The particle passes undeviated through the region of the two fields.

On Fig. 9.1, sketch the path of a particle that has

- (i) mass  $m$ , charge  $+2q$  and velocity  $v$  (label this path Q), [1]
- (ii) mass  $m$ , charge  $+q$  and velocity slightly larger than  $v$  (label this path V). [2]

[Total: 9]

- 10 (a) A metal surface is illuminated with light of a single wavelength  $\lambda$ .  
 On Fig. 10.1, sketch the variation with  $\lambda$  of the maximum kinetic energy  $E_{\text{MAX}}$  of the electrons emitted from the surface.  
 On your graph mark, with the symbol  $\lambda_0$ , the threshold wavelength.

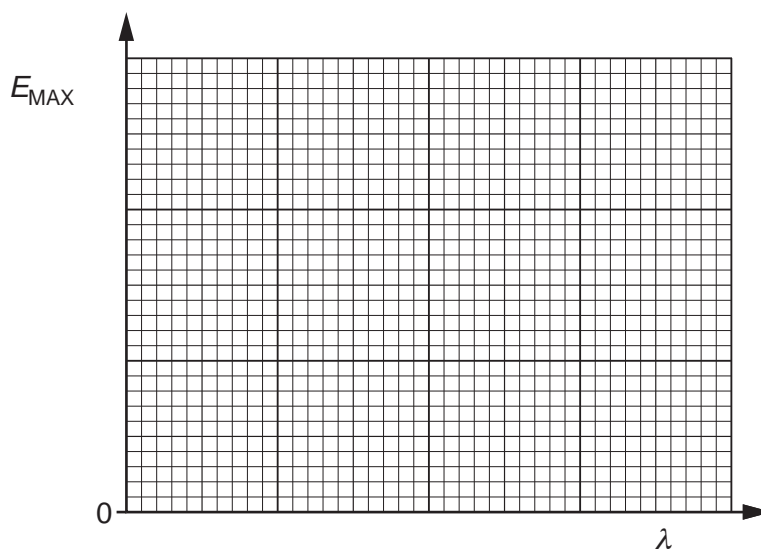

Fig. 10.1

[3]

- (b) A neutron is moving in a straight line with momentum  $p$ .  
 The de Broglie wavelength associated with this neutron is  $\lambda$ .  
 On Fig. 10.2, sketch the variation with momentum  $p$  of the de Broglie wavelength  $\lambda$ .

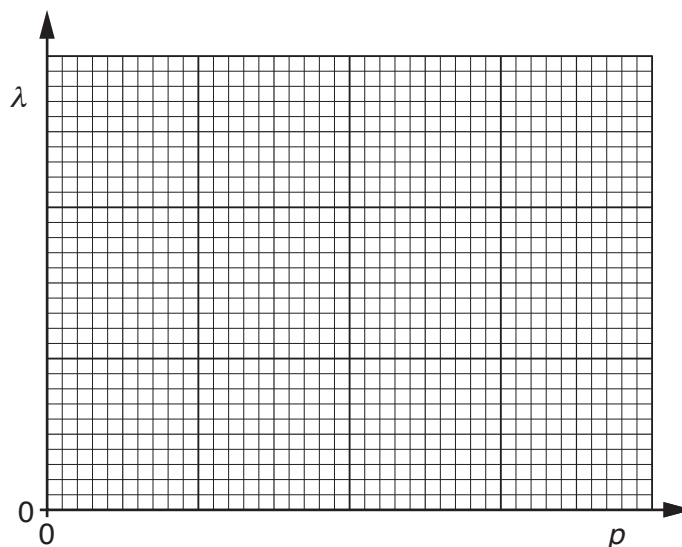

Fig. 10.2

[2]

[Total: 5]

11 The circuit for a full-wave rectifier using four ideal diodes is shown in Fig. 11.1.

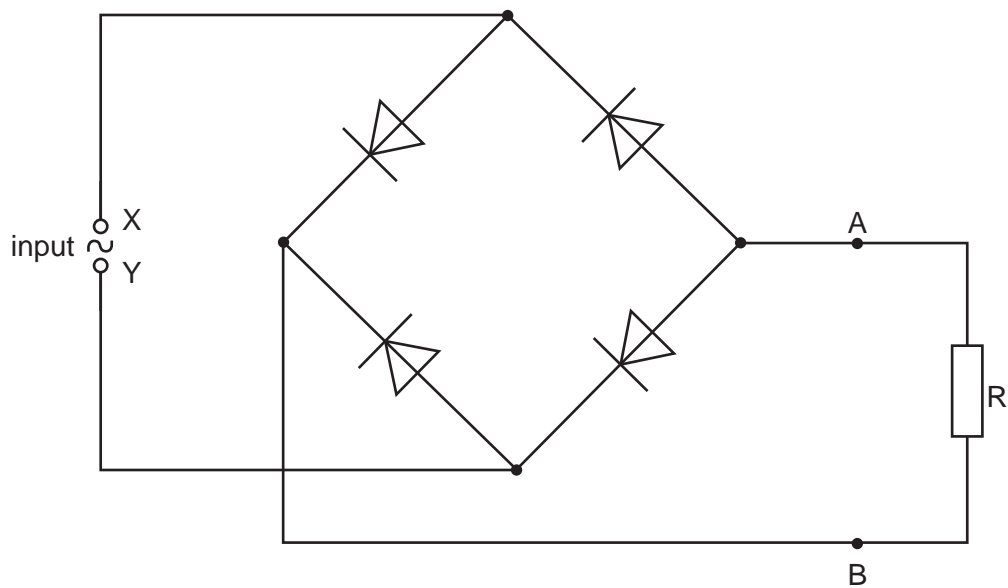

Fig. 11.1

A resistor  $R$  is connected across the output  $AB$  of the rectifier.

(a) On Fig. 11.1,

- (i) draw a circle around any diodes that conduct when the terminal  $X$  of the input is positive with respect to terminal  $Y$ , [1]
- (ii) label the positive (+) and the negative (–) terminals of the output  $AB$ . [1]

- (b) The variation with time  $t$  of the potential difference  $V$  across the input XY is given by the expression

$$V = 5.6 \sin 380t$$

where  $V$  is measured in volts and  $t$  is measured in seconds.

The variation with time  $t$  of the rectified potential difference across the resistor R is shown in Fig. 11.2.

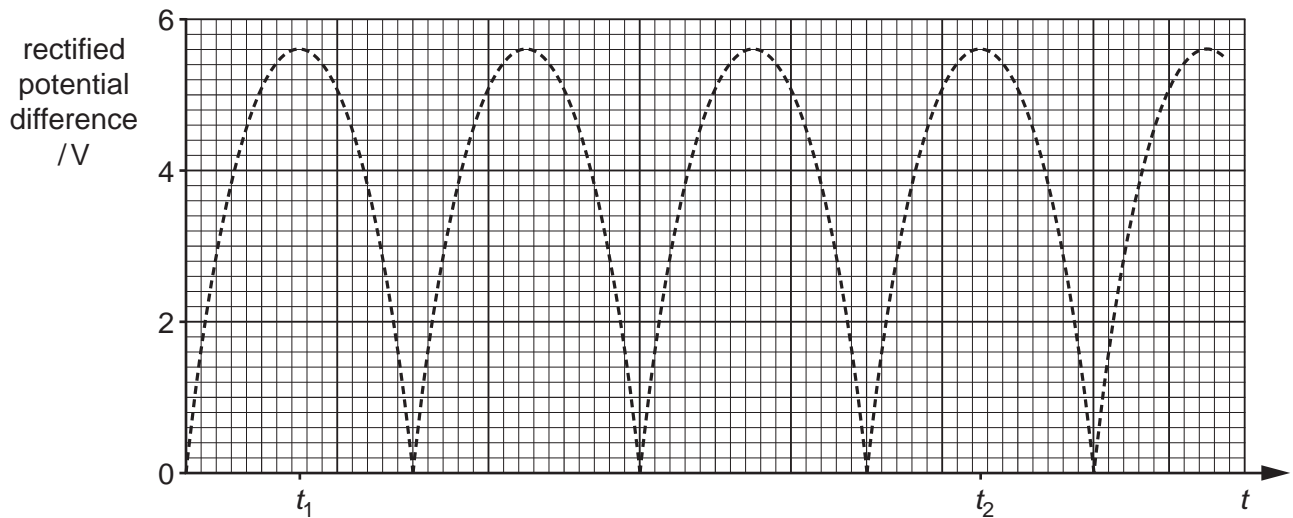

Fig. 11.2

Use the expression for the input potential difference  $V$ , or otherwise, to determine

- (i) the root-mean-square (r.m.s.) potential difference  $V_{\text{r.m.s.}}$  of the input,

$$V_{\text{r.m.s.}} = \dots\dots\dots \text{ V [1]}$$



- (ii) the number of times per second that the rectified potential difference at the output reaches a peak value.

number = ..... [2]

- (c) A capacitor is now connected between the terminals AB of the output.  
The capacitor reduces the variation (the ripple) in the output to 1.6 V.

- (i) On Fig. 11.2, sketch the variation with time  $t$  of the smoothed output voltage for time  $t = t_1$  to time  $t = t_2$ . [4]

- (ii) Suggest and explain the effect, if any, on the mean power dissipation in resistor R when the capacitor is connected between terminals AB.

.....  
 .....  
 ..... [2]

[Total: 11]

- 12 The isotope iodine-131 ( $^{131}_{53}\text{I}$ ) is radioactive with a decay constant of  $8.6 \times 10^{-2} \text{ day}^{-1}$ .  $\beta^-$  particles are emitted with a maximum energy of 0.61 MeV.

(a) State what is meant by

(i) *radioactive*,

.....  
 .....  
 ..... [2]

(ii) *decay constant*.

.....  
 .....  
 ..... [2]

(b) Explain why the emitted  $\beta^-$  particles have a range of energies.

.....  
 .....  
 ..... [2]

(c) A sample of blood contains  $1.2 \times 10^{-9} \text{ g}$  of iodine-131.

Determine, for this sample of blood,

(i) the activity of the iodine-131,

activity = ..... Bq [3]

27

- (ii) the time for the activity of the iodine-131 to be reduced to 1/50 of the activity calculated in (i).

time = ..... days [2]

[Total: 11]

**BLANK PAGE**

---

Permission to reproduce items where third-party owned material protected by copyright is included has been sought and cleared where possible. Every reasonable effort has been made by the publisher (UCLES) to trace copyright holders, but if any items requiring clearance have unwittingly been included, the publisher will be pleased to make amends at the earliest possible opportunity.

To avoid the issue of disclosure of answer-related information to candidates, all copyright acknowledgements are reproduced online in the Cambridge International Examinations Copyright Acknowledgements Booklet. This is produced for each series of examinations and is freely available to download at [www.cie.org.uk](http://www.cie.org.uk) after the live examination series.

Cambridge International Examinations is part of the Cambridge Assessment Group. Cambridge Assessment is the brand name of University of Cambridge Local Examinations Syndicate (UCLES), which is itself a department of the University of Cambridge.